

CLASSICAL AND MODERN CONTROL SYSTEMS OF SELF-EXCITED INDUCTION GENERATOR

Fahim KHALIFA
Suez-Canal University - Egypt

Waheed SABRY
Egyptian Armed Forces

Abdelfattah ELIWA
Egyptian Armed Forces

Mohamed ABDELRAHMAN
Egyptian Armed Forces

ABSTRACT

The main objective of this paper is to design a computer-based controller for the capacitor self-excited induction generator (CSEIG) using terminal capacitors. The generator is assumed to be a power source in an isolated system. System voltage regulation will be the major requirement of the designed controller. This will be achieved by regulating the generator exciting capacitance in response to changes in system operating conditions. An implementation of three types of controllers; PI, PID and Fuzzy Logic Controllers (FLC) is developed. The influence of these control methods on the performance characteristics of the system under consideration is examined. Also, a computer simulation using the MATLAB package is designed to assist the experimental decision for the best control action. The obtained simulation and implementation results are investigated and discussed.

INTRODUCTION

At the down of 20th century, with the continuous demand of energy and cost increase of different types of fuel, the efforts were continued in the direction of depletion of this gap. So, it is necessary to investigate and develop alternative energy sources. Of these sources, the renewable energy sources, and wind energy seems to be a promising alternative to classical energy sources. Different reasons directed all researches to the wind energy, mainly because it does not cause environmental contamination and at most sites, its seasonal availability shows a good correlation with the seasonal demand for energy [1-2].

Over the last ten years, the U.S. National Renewable Energy Laboratory (NREL) has developed new methods to more accurately assess, the wind resource and produce detailed high-resolution (1 km^2) wind maps for essentially anywhere in the world. According to these advancements the wind atlases are designed to include information and wind power classifications specific for both small rural-power applications and large utility-scale applications, as suggested by the photos taken by using upper air (weather balloon) and satellite-derived wind data.

Egypt has established the New and Renewable Energy

Authority (NREA) to be responsible for the study and execution the national program for the use of wind energy. The NREA is promoting progressively the development of wind energy and has started the construction of a wind farm with a total of 600 MW in two stages each of 300 MW at Zaffarana and Suez gulf that already went in operation by the end of year 2005. One of the problems that wind energy will create in such exist electrical power system, is the dependence of the injected power on the wind speed which can not be predicted, but the probability of a particular wind speed occurring can be estimated [3].

At the same time, time series of wind speeds and directions were collected over ten minute's intervals for the period of four years (1995-1998) at a meteorological tower. The wind direction was divided into twelve 30o sectors and the weighted average wind speed (m/s) was calculated on hourly basis. The wind variation for a typical site is usually described using the so-called Weibull Distribution, to measure wind speeds throughout a year.

The erection of wind turbines in power systems has developed rapidly through the last 25 years. The national and international growth rates and policies indicated that this development would continue. Various schemes for generating electricity from the wind turbines have been proposed. These schemes can be classified into: constant speed constant frequency system (CSCF), variable speed constant frequency system (VSCF) and variable speed variable frequency system (VSVF) [1-2].

This paper presents the implementation details of the proposed VSVF wind energy power system that consists mainly of the induction generator operating in the self-excited mode (CSEIG), the exciting capacitor and the load as shown in Figure (1).

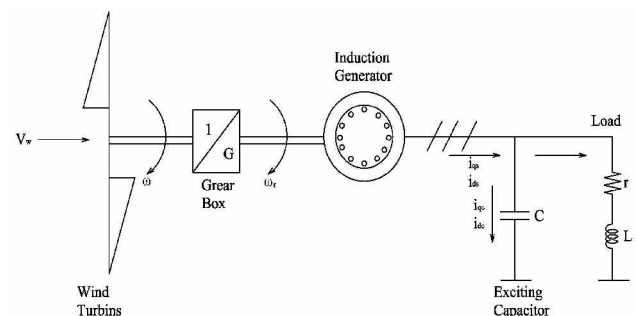

Figure (1): Wind energy conversion system

CONTROL SYSTEM IMPLEMENTATION

The proposed VSVF wind energy power system described in Figure (1); is implemented. Mainly, it consists of a variable speed DC motor representing the wind turbine attached with its gear box, CSEIG, tachogenerator, transducer, 3-phase controller, load and the computer control system. The generator is driven by the variable speed DC motor. Transducer is the measuring unit that used to monitor the state variables of the controlled process. In this work, one feedback signal is used (the terminal voltage V_t of the induction generator). The terminal voltage measuring circuit delivers a dc voltage proportional to the r.m.s. value of the generator voltage. The 3-phase control unit consists of a fixed DC power supply and a 3-phase control circuit. The fixed DC power supply structured from the LM7815 and LM7819 positive and negative regulators.

The circuit diagram of the 3-phase control circuit is shown in Figure (2). It is used to determine the firing instant that issues the firing pulses to the triac of the thyristor-controlled reactor. It is supplied by a dual power supply (± 15 V-DC). The main element of this circuit is the UAA 146, which is monolithic integrated circuit.

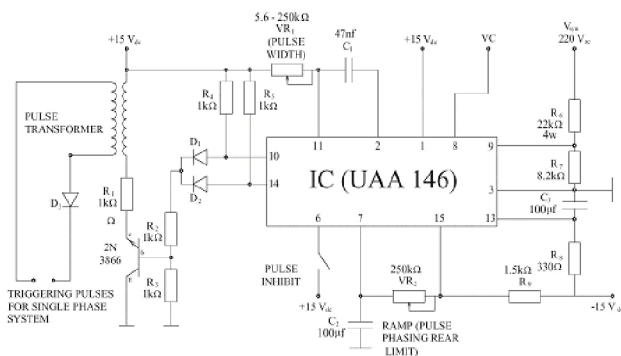

Figure (2): Control circuit for a single-phase of the 3-phase system

The output of the control circuit is composed of two separate pulses synchronized with the ac supply voltage (the terminal voltage of the IG). The phase angle can be varied from 0 to 180° . The pulse transformer (PT) is used to isolate the output pulses from the control circuit. The most feasible way of implementing a digital controller is through the use of a digital computer. Voltage and reactive power control, which is the aim of this section, has grown in importance for a number of reasons; first, the requirement for more efficient operation of power systems has increased with the increase of fuel price. Second, the requirement for high quality of supply has increased due to the huge demand of the electronic equipment. Voltage and

reactive power control is an essential tool in maintaining the quality of supply, especially in preventing voltage disturbance, which is the commonest type of disturbances.

FLC, PI AND PID CONTROLLERS

Three types of controllers were used, FLC, PI and PID. The MATLAB SIMULINK models for the three controller using MATLAB toolbox were used. In this model, there are two analog input signals; the first is the generator output voltage, which comes from a measurement circuit through an A/D converter. The signal is filtered then compared with the reference voltage, result an error signal. The second is the prime mover speed, which is measured through a tachogenerator and A/D converter. The output voltage error signal is processed in a discrete PID controller to get a control signal, which conditioned through a saturation block and a D/A converter. Then the output analog control voltage is used to drive the (FC-TCR) VAR circuit.

SIMULATION RESULTS

The system parameters, constants and initial conditions are given in such away that the performance is to be as near as possible to experimental model. The simulation results are recorded for different disturbances that the system can be subjected to. Also, the influence of different control schemes on the system response is also considered. A comparison study of the effectiveness of the proposed control techniques on the system performance is presented and discussed. In all case studies, the simulation period is selected to be 6 seconds. Two cases are selected to demonstrate the output simulation results: step increase in the resistive load by 20% and step increase in wind speed by 10%. Figures (3, 4 and 5) show the system behavior following a step increase in the resistive load by 20% occurs. Figures (6, 7 and 8) show the system behavior following a step increase in wind speed by 10% occurs.

EXPERIMENTAL RESULTS

The experimental results of the power system under study are investigated when the system is equipped with the three proposed controllers; PI controller, PID controller, and FLC. For each control system, the following case studies are considered: 75% loading (3/4 load) condition, 100% loading (full load) condition, step increase in reference voltage by 5% and step decrease in reference voltage by 10%. The signal of terminal voltage in each case was monitored. Figure (9) shows the terminal voltage-time response with PI, PID and FLC at 75% loading conditions. Figure (10) shows the terminal voltage-time response with PI, PID and FLC at 100% loading conditions. Figure (11) shows the terminal voltage-time response with PI, PID and

FLC due to 5% step increase in reference voltage. Figure (12) shows the terminal voltage-time response with PI, PID and FLC due to 10% step increase in reference voltage.

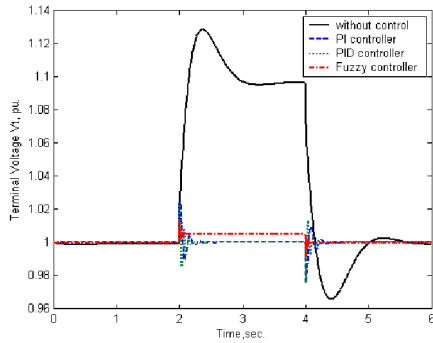

Figure (3): Voltage-time response

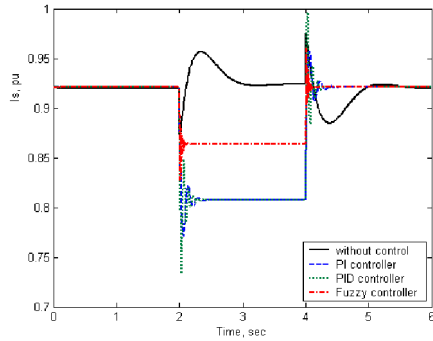

Figure (4): Stator current-time response

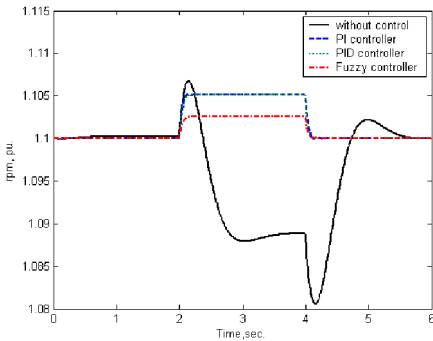

Figure (5): Speed-time response

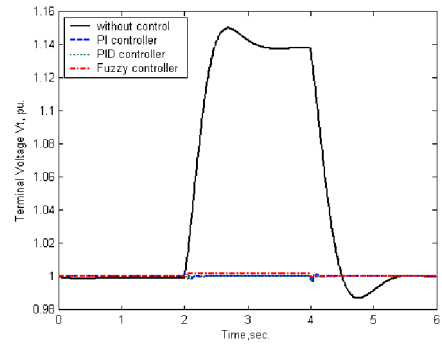

Figure (6): Voltage-time response

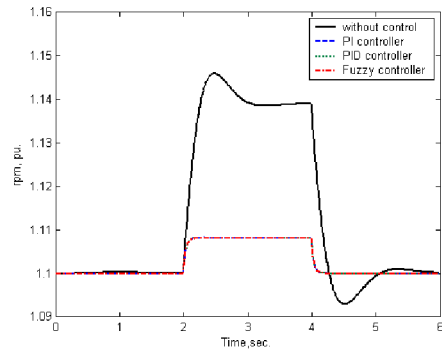

Figure (7): Stator current-time response

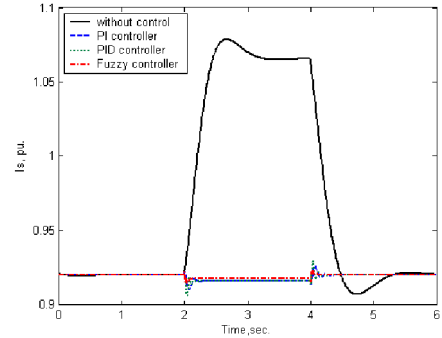

Figure (8): Speed-time response

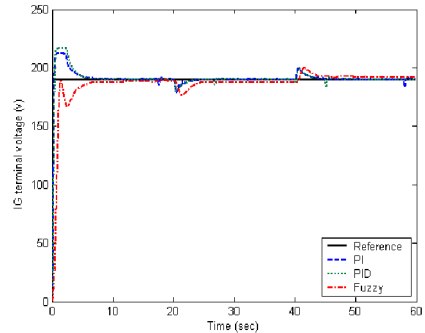

Figure (9): Terminal voltage- time response with PI, PID and FLC at 75% loading conditions

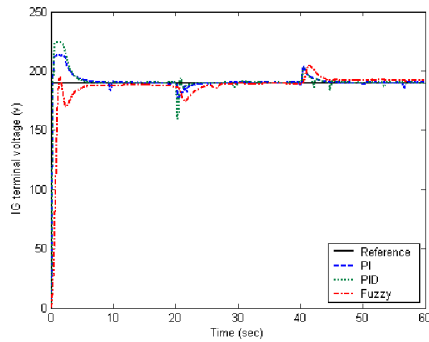

Figure (10): Terminal voltage- time response with PI, PID and FLC at 100% loading conditions

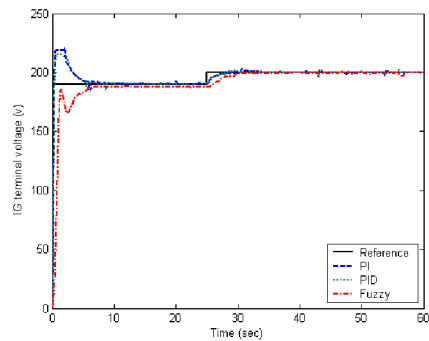

Figure (11): Terminal voltage- time response with PI, PID and FLC due to 5% step increase in reference voltage

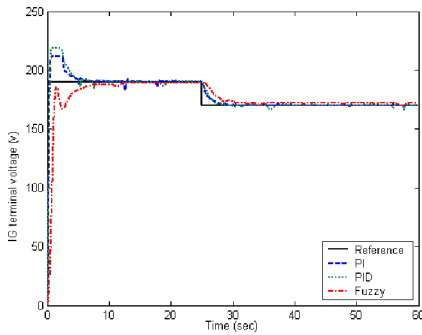

Figure (12): Terminal voltage- time response with PI, PID and FLC due to 10% step increase in reference voltage

DISCUSSION OF THE RESULTS

Simulation results

For simulation results and in the case of a step increase in the resistive load by 20%, the three types of controllers showed a better performance than that if the system is without control. The FLC showed slightly better performance than PI and PID controllers.

Experimental results

For experimental results and in the first two case studies, the proposed controllers are introduced when the system is

operating at no-load. The load is applied after 20 seconds with the predestining value according to each case study and it's sustained for 20 seconds, then it will be removed. In the last two case studies, the system responses with the proposed controllers are investigated when the system is subjected to step increase in the reference voltage by 5% and step decrease in the reference voltage by 10% after 25 second from the simulation starting time. A comparison between the IG performances as presented by its terminal voltage-time response is demonstrated when equipped with FLC, PI and PID controllers. It can be seen from investigating the machine response curves that the transient performance of the system when equipped with the different control strategies mentioned above is acceptable. However a better transient response and damping characteristic is obtained with FLC. The tuning difficulties associated with PID controllers to the variations of the system operating conditions, makes the application of FLC is preferable.

CONCLUSION

A simulation and implementation study of the performance characteristics of the induction generator when equipped with static VAR compensator (SVC) is demonstrated. A design and realization of this static VAR compensator is also demonstrated. It consists of three-phase thyristor controlled reactors and three phase fixed capacitor. The control circuit is also designed and realized. FLC is very efficient in improving both transient and dynamic characteristics of the system under study.

REFERENCES

- [1] James F. Manwell and Duane E. Cramack, January 1990, "Understanding wind energy", <http://www.vita.org>, *Volunteers in technical assistance*, Technical part 11, 1-20.
- [2] Hani Khaled, 1990, "Computer control of wind driven induction generator system", *Ph.D. thesis, MTC, Cairo*.
- [3] Mohamed El-Sayed , Mohamed Salah El-Sobki and Effat Moussa, December 29-31, 2001, "Wind energy impact on the reliability of Egyptian generation system", *The 8th inter. Middle East power system conference (MEPCON), Uni. of Helwan, Egypt*, 975-981.
- [4] Abd-El-Fatah El-Sayed Elewa, 1994, "Influence of static VAR compensator on power system dynamics", *Master thesis, MTC, Cairo*.
- [5] R. Mostafa, A. El-Kosy and U. Abo-Zayed, August 1999, "Simulation of Fuzzy controlled disc type DC motor fed from quasi resonant converter using simulink", *9th inter. Conf. on computer theory and applications, ICCTA 99, Alexandria, Egypt*, 15-23.